

Sospensioni anti-rotative angolari con corpo liscio / Smooth-body non-rotative suspensions with integral elbow arms

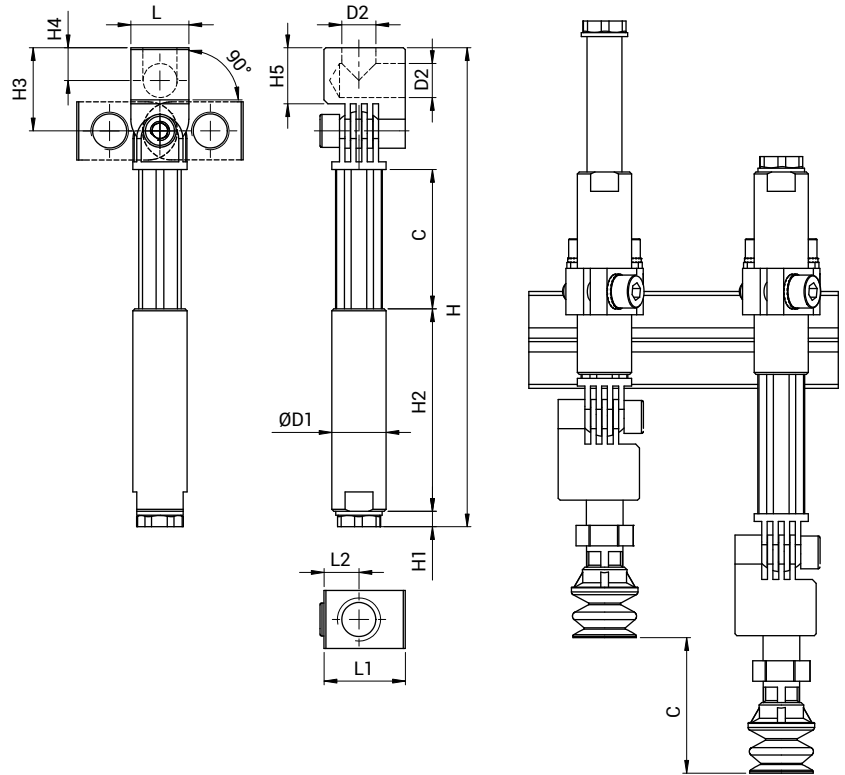

ARTICOLO ARTICLE	H [mm]	H1 [mm]	H2 [mm]	H3 [mm]	H4 [mm]	H5 [mm]	D1	D2	L [mm]	L1 [mm]	L2 [mm]	C [mm]	MATERIALE MATERIAL	PESO WEIGHT
SEARS1420F18	91	4	35	21.5	8.5	14.5	14	G1/8"	15	21	9	20	Alluminio / Aluminium	45 g
SEARS1435F18	124	4	52.5	21.5	8.5	14.5	14	G1/8"	15	21	9	35	Alluminio / Aluminium	55 g
SEARS2025F18	124.5	3	58.5	24.5	8.5	14.5	20	G1/8"	17	27	12	25	Alluminio / Aluminium	70 g
SEARS2050F18	181.5	3	90.5	24.5	8.5	14.5	20	G1/8"	17	27	12	50	Alluminio / Aluminium	90 g
SEARS2025F14	131.5	3	58.5	31.5	12	21.5	20	G1/4"	17	27	12	25	Alluminio / Aluminium	105 g
SEARS2050F14	188.5	3	91	31.5	12	21.5	20	G1/4"	17	27	12	50	Alluminio / Aluminium	120 g

esempi di utilizzo / application example

