

## Staffa di fissaggio lunga / Mounting bracket

- QC**  
CAMBIO RAPIDO
- BP**  
INTERFACCE
- SQ**  
TRAVI QUADRE
- NUT**  
DADI
- TB**  
PROFILI
- CC**  
STAFFE ANGOLARI TRAVI
- SFP**  
PIASTRE DI FISSAGGIO
- MB**  
MODULI PER STRUTTURA E FISSAGGIO
- CL - EA**  
GOMITI CON CRAVATTA
- DS**  
DISTRIBUTORI
- LVC - EAV - AVL**  
GAMBI E GOMITI PER VENTOSA
- CNT**  
PINZE MATEROZZA
- ET**  
PROLUNGHE
- AD**  
STAFFA FISSAGGIO PINZA
- SG**  
PINZE MATEROZZA
- AG**  
PINZE ANGOLARI
- PG**  
PINZE PARALLELE
- OFG**  
PINZE PNEUMATICHE
- NB**  
ATTUATORI AUTOMATICI
- W.N**  
LAME STANDARD
- BH**  
CORPI PORTA LAMA SPECIALI
- W.S**  
LAME SPECIALI
- CVA**  
CILINDRO ANTIROTAZIONE
- SR - SA - SS**  
COMPENSATORI
- V - SV**  
VENTOSE
- RAP**  
RACCORDI

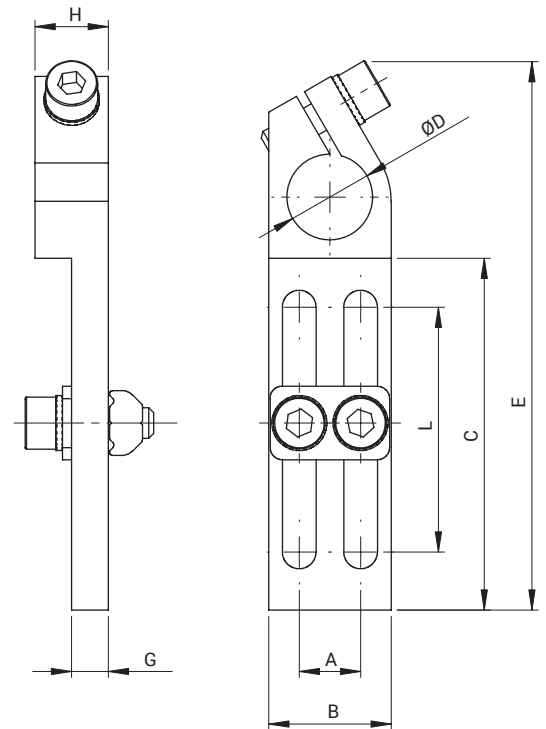

ARTICOLO ARTICLE	A [mm]	B [mm]	C [mm]	Ø D [mm]	E [mm]	F [mm]	G [mm]	H [mm]	L [mm]	MATERIALE MATERIAL	PESO WEIGHT
<b>MBL-D10-L40</b>	8	16	55	10	77	4	8	8	40	Alluminio / Aluminium	23 g
<b>MBL-D14-L50</b>	10	20	69	14	98	6	12	12	50	Alluminio / Aluminium	40 g
<b>MBL-D20-L60</b>	15	25	80	20	115	6	12	12	60	Alluminio / Aluminium	55 g
<b>MBL-D30-L60</b>	22	35	80	30	127	10	20	20	60	Alluminio / Aluminium	95 g

### esempi di utilizzo / application example

