

Staffa per fissaggio a croce profili / Cross mounting bracket for profiles

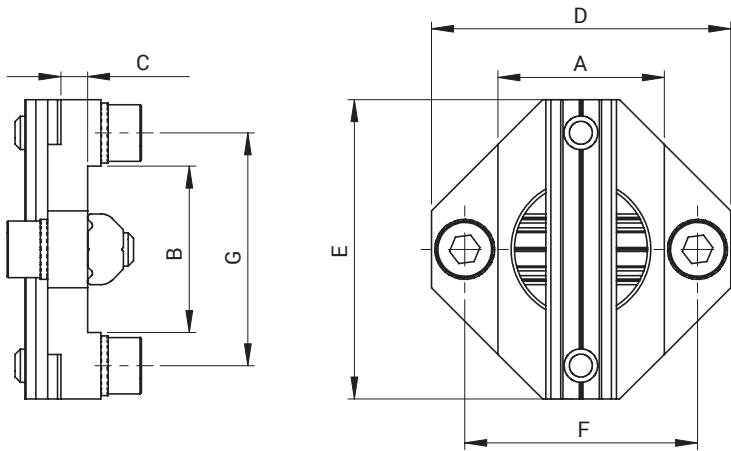

ARTICOLO ARTICLE	A [mm]	B [mm]	C [mm]	D [mm]	E [mm]	F [mm]	G [mm]	MATERIALE MATERIAL	PESO WEIGHT
MBC-1818	18	18	2	38	38	38	28	Alluminio / Aluminium	40 g
MBC-2525	25	25	4	45	45	35	35	Alluminio / Aluminium	75 g
MBC-2550	25	50	4	45	70	35	60	Alluminio / Aluminium	155 g
MBC-4040	40	40	4	60	60	50	50	Alluminio / Aluminium	85 g
MBC-5050	50	50	4	70	70	60	60	Alluminio / Aluminium	170 g

esempi di utilizzo / application example

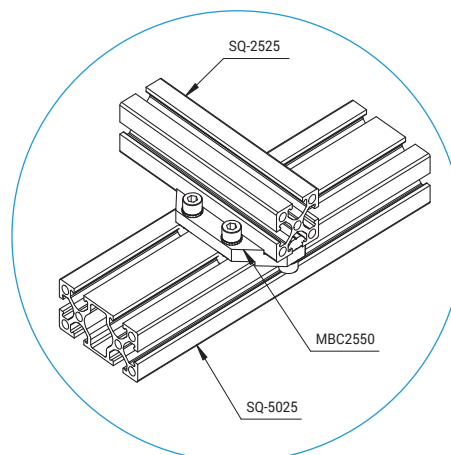
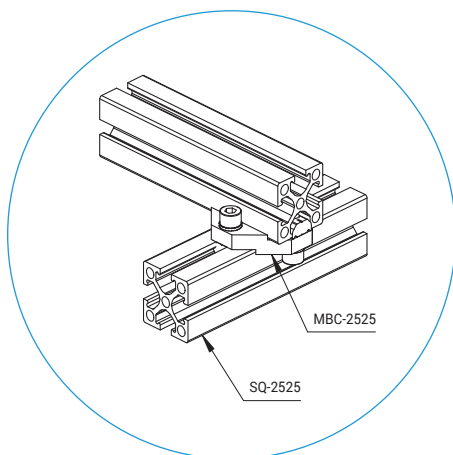

QC
CAMBIO RAPIDO

BP
INTERFACCIE

SQ
TRAVI QUADRE

NUT
DADI

TB
PROFILI

CC
STAFFE ANGOLARI TRAVI

SFP
PIASTRE DI FISSAGGIO

MB
MODULI PER STRUTTURA
E FISSAGGIO

CL - EA
GOMITI CON CRAVATTA

DS
DISTRIBUTORI

LVC - EAV - AVL
GAMBI E GOMITI
PER VENTOSA

CNT
PINZE MATEROZZA

ET
PROLUNGHE

AD
STAFFA FISSAGGIO PINZA

SG
PINZE MATEROZZA

AG
PINZE ANGOLARI

PG
PINZE PARALLELE

OFG
PINZE PNEUMATICHE

NB
ATTUATORI AUTOMATICI

W.N
LAME STANDARD

BH
CORPI PORTA LAMA
SPECIALI

W.S
LAME SPECIALI

CVA
CILINDRO ANTIROTAZIONE

SR - SA - SS
COMPENSATORI

V - SV
VENTOSE

RAP
RACCORDI