

## Staffe angolari travi / Corner Connectors 90°

### CC-25

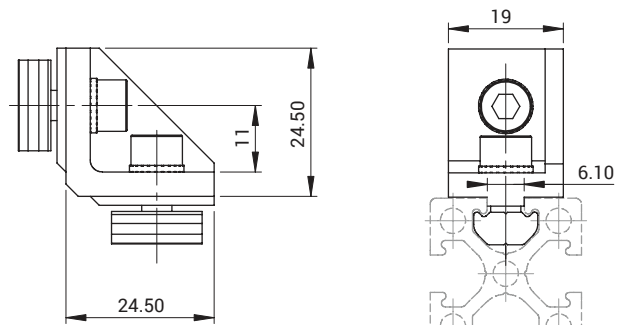

### CC-50

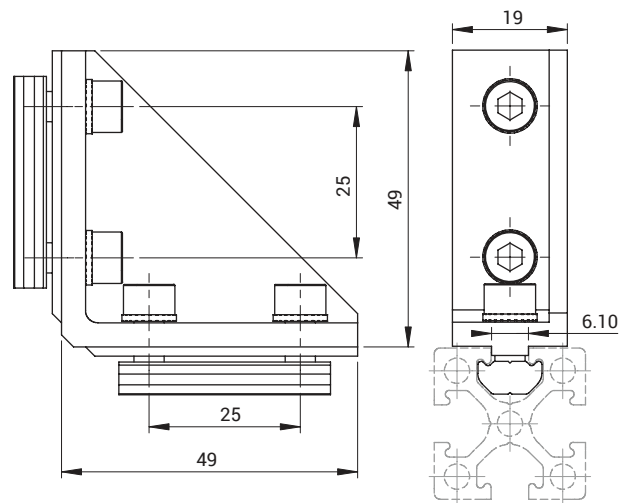

ARTICOLO ARTICLE	MATERIALE MATERIAL	PESO WEIGHT
CC-25	Alluminio / Aluminium	33 g
CC-50	Alluminio / Aluminium	82 g

### esempi di utilizzo / application example

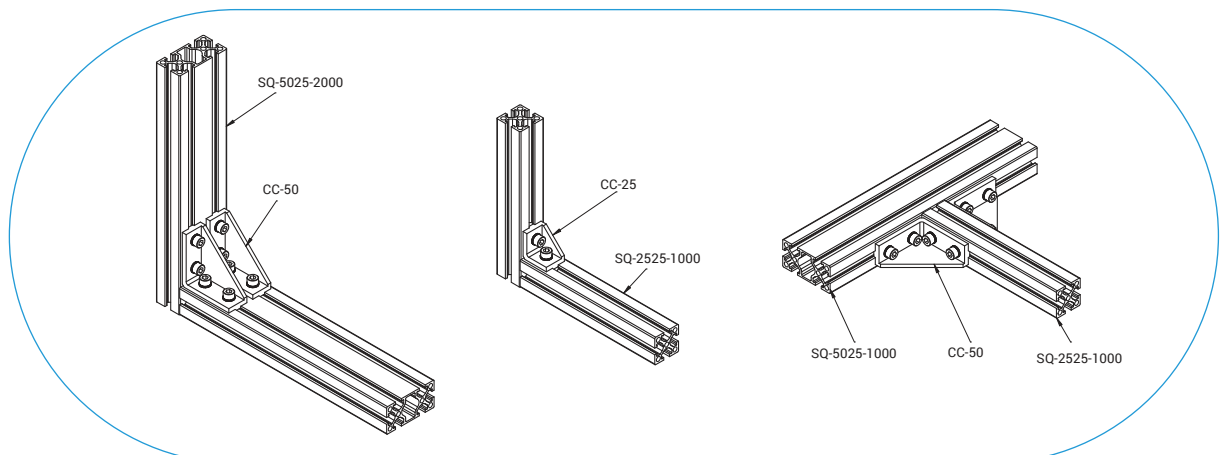

- QC**  
CAMBIO RAPIDO
- BP**  
INTERFACCE
- SQ**  
TRAVI QUADRE
- NUT**  
DADI
- TB**  
PROFILI
- CC**  
STAFFE ANGOLARI TRAVI
- SFP**  
PIASTRE DI FISSAGGIO
- MB**  
MODULI PER STRUTTURA E FISSAGGIO
- CL - EA**  
GOMITI CON CRAVATTA
- DS**  
DISTRIBUTORI
- LVC - EAV - AVL**  
GAMBI E GOMITI PER VENTOSA
- CNT**  
PINZE MATEROZZA
- ET**  
PROLUNGHE
- AD**  
STAFFA FISSAGGIO PINZA
- SG**  
PINZE MATEROZZA
- AG**  
PINZE ANGOLARI
- PG**  
PINZE PARALLELE
- OFG**  
PINZE PNEUMATICHE
- NB**  
ATTUATORI AUTOMATICI
- W.N**  
LAME STANDARD
- BH**  
CORPI PORTA LAMA SPECIALI
- W.S**  
LAME SPECIALI
- CVA**  
CILINDRO ANTIROTAZIONE
- SR - SA - SS**  
COMPENSATORI
- V - SV**  
VENTOSE
- RAP**  
RACCORDI