

Staffa fissaggio pinza / Adapter gripper

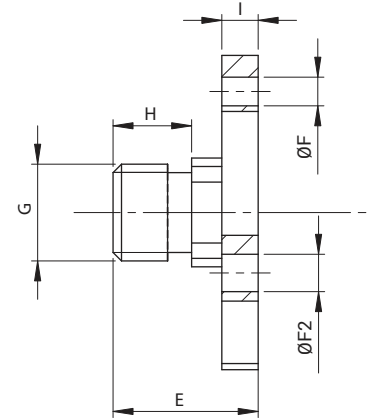

ARTICOLO ARTICLE	PER FOR	A [mm]	B [mm]	C [mm]	C1 [mm]	D [mm]	D1 [mm]	E [mm]	G [mm]	H [mm]	ØF [mm]	ØF1 [mm]	I [mm]	MATERIALE MATERIAL	PESO WEIGHT
AD-PGS20	PGS-20	16	20	15	8	8	3	11	M8x1	6.5	2.6	2.6	3	Alluminio / Aluminium	5 g
AD-PGS25	PGS-25	18	26	20	10	9	3	12	M8x1	6.5	3.1	3.1	3	Alluminio / Aluminium	7 g
AD-PGS32	PGS-32	22	32	25	10	11	3	12	M8x1	6.5	4.2	3.1	3	Alluminio / Aluminium	9 g

esempi di utilizzo / application example

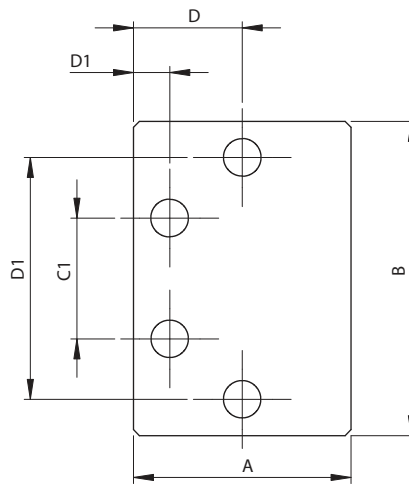